

# PRECISION REGULATOR WITHOUT CONSTANT BLEED, UP TO 16 BAR OUTLET PRESSURE R217

<b>Description</b>	Diaphragm pressure regulator with good regulation accuracy at varying volume flow.		
<b>Media</b>	compressed air or non-corrosive gases		
<b>Supply pressure</b>	max. 16 bar		
<b>Accuracy</b>	response sensitivity: < 350 mbar		
<b>Air consumption</b>	without constant bleed		
<b>Adjustment</b>	by handwheel with locknut, suitable for panel mounting		
<b>Relieving function</b>	relieving		
<b>Gauge port</b>	G $\frac{1}{4}$ on both sides of the body, one screw plug supplied		
<b>Mounting position</b>	any		
<b>Temperature range</b>	0 °C to 80 °C / 32 °F to 176 °F		
<b>Material</b>	Body: zinc die-cast	O-ring: NBR/Buna-N	
	Spring cage: zinc die-cast	Bottom screw: POM	
	Diaphragm: FKM		

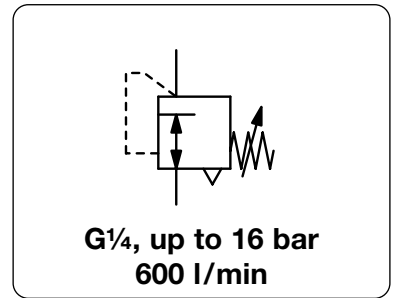

Dimensions			K <sub>v</sub> -value (m <sup>3</sup> /h)	Flow rate m <sup>3</sup> /h*1 l/min*1	Connection thread G	Pressure range bar	Order number
A	B	C					

Precision pressure regulator							supply pressure max. 16 bar, relieving, without constant bleed	R217
82	148	20	0,3	36	600	G $\frac{1}{4}$	0,01 ... 0,5	R217-020
							0,01 ... 1	R217-02A
							0,20 ... 3	R217-02B
							0,40 ... 6	R217-02C
							0,50 ... 10	R217-02D
							0,70 ... 16	R217-02E

**Special options, add the appropriate letter**

free of grease and oil specially cleaned R217-0..L



**Accessories, enclosed**

pressure gauge Ø 63 mm, 0...\*2 bar, G $\frac{1}{4}$  MA6302-...\*2

mounting bracket made of steel BW00-36

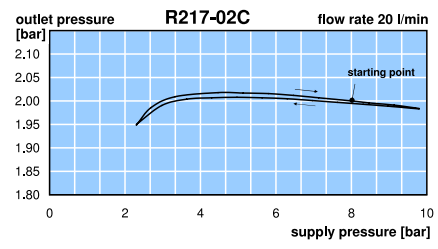
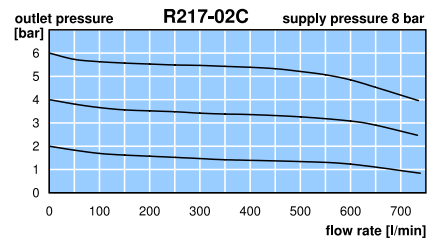
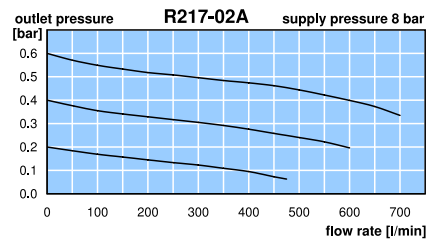
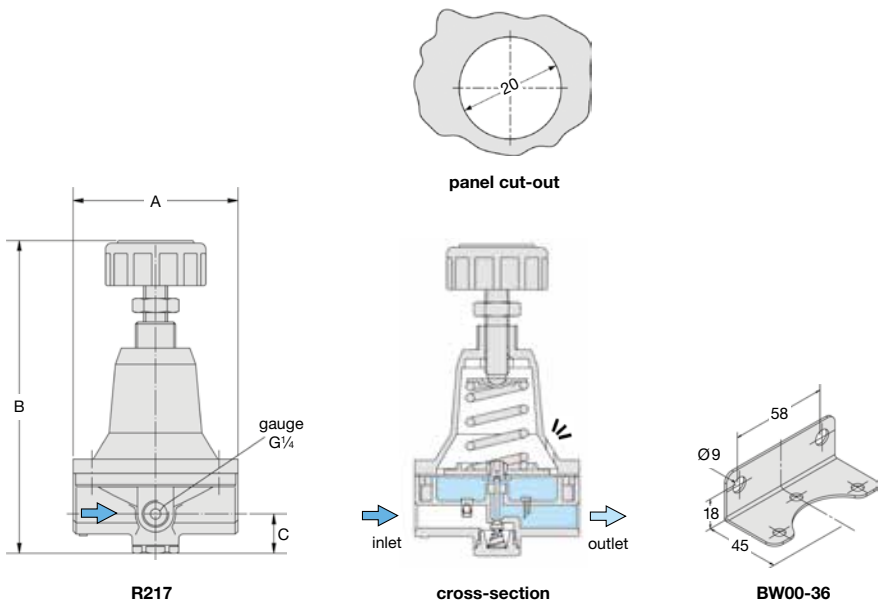
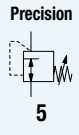

\*1 at 8 bar supply pressure, 6 bar outlet pressure und 1 bar pressure drop  
\*2 01 = 0...1 bar, 04 = 0...4 bar, 06 = 0...6 bar, 10 = 0...10 bar, 16 = 0...16 bar